

NEUROCOMPUTATIONAL ANALYSIS OF A FREQUENCY RECONFIGURABLE ANTENNA

Amalendu Patnaik⁽¹⁾, Christos G. Christodoulou⁽²⁾

⁽¹⁾Department of Electronics and Communication Engineering
National Institute of Science & Technology, Berhampur – 761 008, Orissa, India
E-mail: apatnaik@ieee.org

⁽²⁾Department of Electrical and Computer Engineering,
The University of New Mexico, Albuquerque, NM 87131, USA
E-mail: christos@ece.unm.edu

Abstract – Neural network implementation procedures are developed for characterizing multiband reconfigurable antennas. A multilayer perceptron (MLP) neural network is used to locate the operational frequency bands of the antenna at different reconfigured conditions. Another self-organizing map (SOM) neural network accomplishes the task of locating the switches to be turned ON for a desired frequency response. The developed formulation is tested on a laboratory prototype antenna. This neurocomputational methodology can also be extended for characterizing any reconfigurable electromagnetic structure.

I. INTRODUCTION

In response to the ever-increasing needs of antenna bandwidth, considerable amount of effort is currently underway to develop reconfigurable antenna systems [1-2]. The technology of design and fabrication of microelectromechanical systems (MEMS) for RF circuits has put a major positive impact on reconfigurable antennas [3]. These antennas are complex electromagnetic structures comprising of planar radiators that are switched using a network of switches. Due to the multiscale nature of reconfigurable antennas, a single analytical method cannot characterize the whole structure. On the other hand, the use of different analytical methods for a single structure makes it a computationally intensive task, leading to the use of heavy computational resources. So there is a need to search for an analysis procedure for reconfigurable antennas that can characterize the antenna accurately.

This paper focuses on the use of neural networks (NNs) for analysis and design of a frequency reconfigurable antenna. NNs have emerged in recent years as a powerful technique for modeling general input-output relationships. The distinguished characteristics of NNs such as learning from data, to generalize patterns in data and to model nonlinear relationships, makes them a good candidate to apply for many different branches of engineering. In this work, we have used two different neural architectures for analysis and design of a reconfigurable antenna. In the analysis phase, NNs are used to locate the operational frequency bands for different reconfigurable structures of the antenna. This is treated as a mapping formation problem and is accomplished by a *Multilayer Perceptron* neural network trained in

the backpropagation mode [4]. In the design phase, the job of the NN is to determine the switches that are to be made ON for the structure to resonate at specific bands. This task is handled as a classification type of problem and is accomplished by a *Self Organizing Map* neural network [5]. The proposed neurocomputational technique is investigated for a laboratory prototype antenna. It drastically reduces the mathematical complexity involved in the different numerical methods used to model the entire reconfigurable antenna due to its multiscale structure. The developed neurocomputational methodology can also be extended for characterizing any reconfigurable electromagnetic structure.

II. THE RECONFIGURABLE ANTENNA STRUCTURE

The proposed neurocomputational technique is investigated for a laboratory prototype antenna. The structure under investigation is shown in Figure 1. The basic antenna is a 130° balanced bowtie. A portion of the antenna corresponds to two iteration fractal Sierpinski dipole. The remaining elements are added (three elements on each side) to make the antenna a more generalized reconfigurable structure. The reason for choosing this structure for modeling is two-fold. First is the multiband behaviour of fractal Sierpinski antenna [6]. The second reason is that the broader angles move the operating bands to lower frequencies, which can be useful to reduce the antenna height. In addition, the input resistance and reactance variations become smoother when opening the flare angle [7].

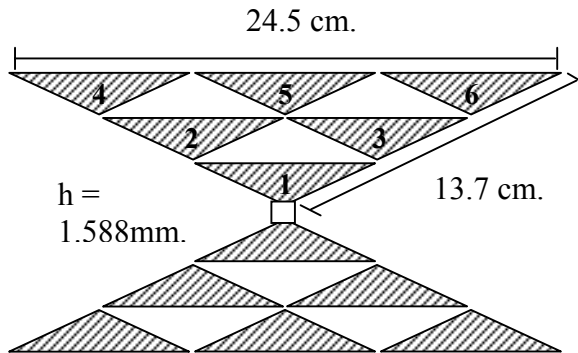

Fig. 1. Multiband antenna under investigation

The antenna was fabricated on a Duroid substrate ($\epsilon_r = 2.2$) with no radiating element touching to their adjacent elements. In the absence of actual MEMS switches, their electromagnetic performance is considered ideal and their placement is accomplished by small physical connections of the antenna's adjacent conducting parts. Our aim in this paper is to show the feasibility of use of NNs as an analysis tool for multiband reconfigurable antennas. With the use of actual MEMS switches, the same technique is equally applicable.

III. APPLYING NEUROCOMPUTATIONAL TECHNIQUE FOR ANALYSIS

The paradigm of application of NN for analysis of the reconfigurable antenna structure is shown in Fig. 2. Measured frequency domain response ($|S_{11}|$) of the antenna for various combination of ON switch positions, using an HP8714ES network analyzer was used as the training data. The operational frequency range of the antenna is 0.1-3.0 GHz. Responses of the NN for some typical structures are shown in Fig. 3.

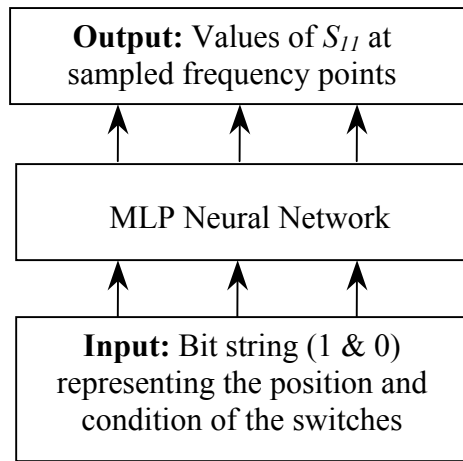

Fig. 2: Paradigm of application of NN for analysis

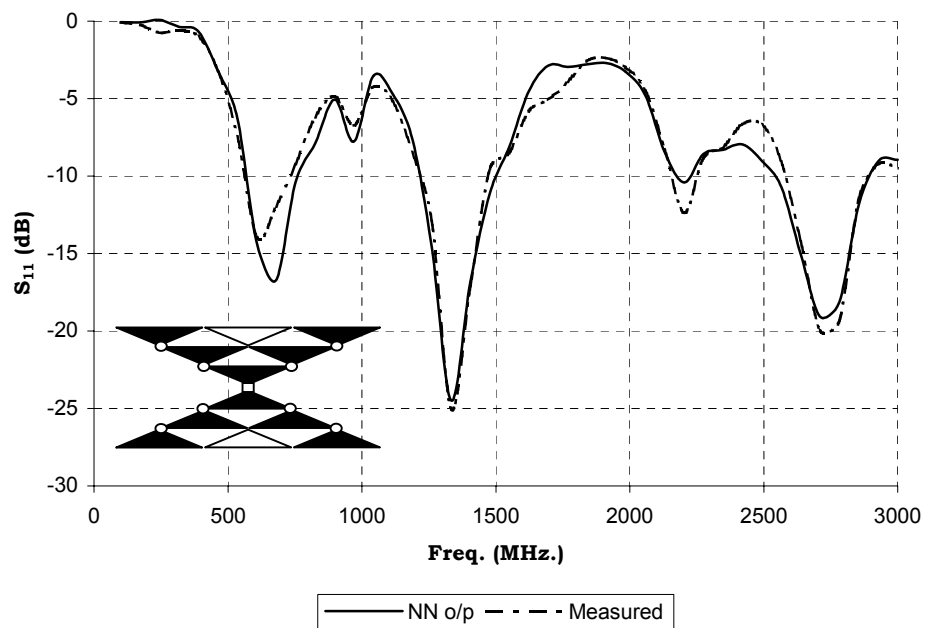
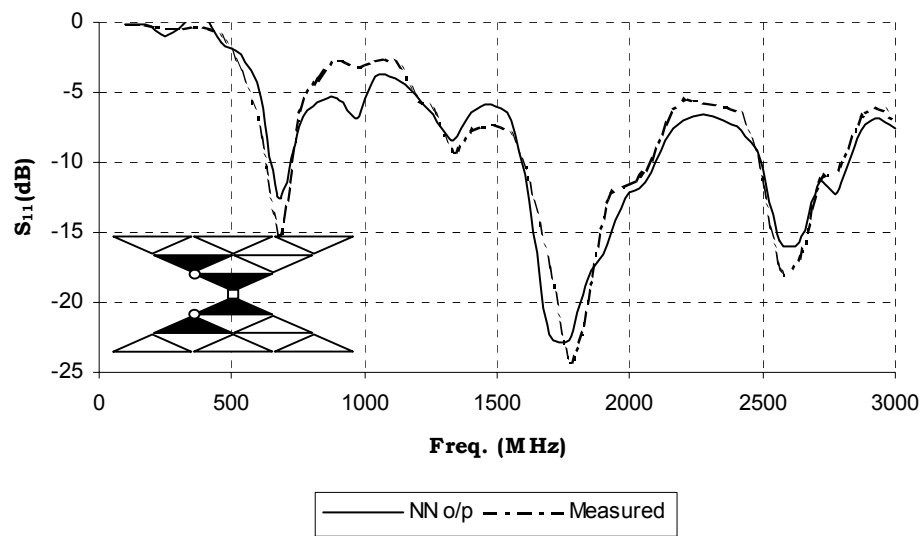

Fig. 3: NN output for some typical structures as compared with measured values

IV. APPLYING NEUROCOMPUTATIONAL TECHNIQUE FOR DESIGN

The paradigm of application of NN for design of reconfigurable structures is shown in Fig. 4.

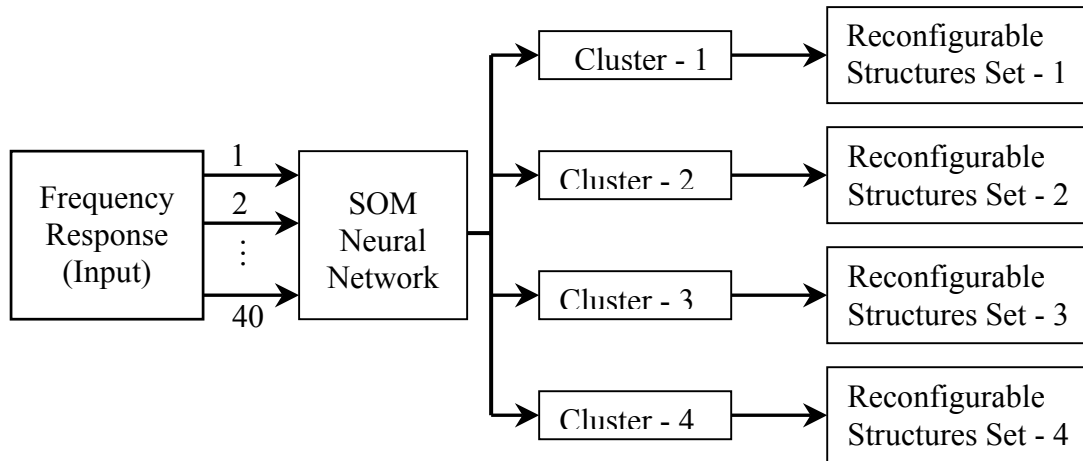

Fig. 4: Paradigm of application of NN for design

V. CONCLUSION

Two different neural network structures are used for analysis and design of a laboratory prototype frequency reconfigurable antenna. The developed neurocomputational methodology can be extended for characterizing any reconfigurable electromagnetic structure. The presentation will include the details of NN implementation and results for analysis and design.

REFERENCES

- [1] K. C. Gupta, J. Li, R. Ramadoss, C. Wang, Y. C. Lee, V. M. Bright, "Design of frequency-reconfigurable rectangular slot ring antennas," *Proc. IEEE Antennas Propagat. Int. Symp.*, Salt Lake City, UT, vol. 1, pp. 326, July 2000.
- [2] M. A. Ali, P. Wahid, "A reconfigurable Yagi array for wireless applications," *Proc. IEEE Antennas Propagat. Int. Symp.*, San Antonio, TX, pp. 466-468, June 2002.
- [3] E. R. Brown, "RF-MEMS switches for reconfigurable integrated circuits," *IEEE Trans. MTT*, vol. 46, no. 11, pp. 1868-1880, 1998.
- [4] S. Haykins, *Neural networks: A comprehensive foundation*, IEEE Press/IEEE Computer Society Press, New York, 1994.
- [5] T. Kohonen, "The self-organizing map," *Proceedings IEEE*, vol. 78, no. 9, pp. 1464-1480, 1990.
- [6] C. Puente, J. Romeu, R. Pous, A. Cardama, "On the behaviour of the Sierpinski multiband antenna," *IEEE Trans. Antennas Propagat.*, vol. 46, pp. 517-524, Apr. 1998.
- [7] C. Puente, M. Navarro, J. Romeu, and R. Pous, Variations on the fractal Sierpinski antenna flare angle, *Proc. 1998 IEEE AP/URSI Symp.*, (1998), 2340-2343.